



More Precision

mainSENSOR // Magneto-inductive displacement sensors





- *Selectable measuring ranges up to 55mm*
- *Linear output signal*
- *High basic sensitivity and temperature stability*
- *Completely non-contact*
- *Wear-free*
- *High dynamics*
- *Scalable to all quantities*

Measuring principle

mainSENSOR is based on an innovative measuring principle, which has been developed by Micro-Epsilon in order to combine the advantages of both inductive and magnetic sensors.

For the measuring, the magnet is fixed to the measuring object. The movement of the magnet results in a change of the magnetic flux within the sensor element, which is detected by a sensor coil. Due to countervailing physical effects in the sensor, a linear relationship between the displacement and output signal is achieved. As different strength magnets are applied, measuring ranges of up to 55mm can be realized. However, for changing measurement set up, it is only necessary to change the magnet. As well as distance and displacement measurement, the sensor can be used for rotational speed measurements of axes or toothed racks.

Flexible sensor concept

Due to their flexible concept, the sensors are ideal for a wide range of applications, particularly where high volumes are required.

The standard sensors are designed in a stainless steel M12, M18 and M30 or a flat plastic housing suitable for industrial applications. The integrated evaluation electronics is situated on a compact PCB. In high volume production, customer-specific modifications to the PCB and sensor housing can be easily implemented.

No calibration required

Due to the automatic linearisation of the sensor, no calibration is required. This offers a decisive benefit when installing multiple sensors. Before starting the operation, a zero point has to be set by positioning the sensor and the magnet. Consequently, the sensors are ready for use within a short time.

Robust sensor design:

- Stainless steel housing, insensitive to dirt, dust, oil etc.
- Protection class up to IP67 and P69K
- Pressure resistant
- Suitable for use in food processing



Application in automation, machine building and OEM

Magneto-inductive sensors from Micro-Epsilon have many potential areas of use, including individual applications in conventional machine building to measurements in automated processes and cost-sensitive high volume production.



Picture: Uhlmann Pac-Systeme GmbH & Co. KG

Foreign body detection in medical technology

In this application, the MDS sensor recognizes foreign bodies in blister machines during the tablet packaging process. Via the movement of overhead touching rollers, foreign bodies between the blister packaging and covering material can be detected. Exceeding a pre-defined point triggers an alarm.



Picture: SIG Combibloc Group AG

Valve lift measurement in the food industry

During the filling of drinks cartons, the exact dosage is a critical factor. The sensor measures the valve lift of the filling line and requests several switching points in a measuring range of 35mm. The sealed stainless steel housings of the MDS-45-Mxx series are ideal for the food industry.



Rotational speed measurement in marine diesel

Integrating the magnet into the sensor housing (magnetic pre-tension) enables the detection of large ferromagnetic particles. This effect is useful for measuring the rotational speed of gear wheels in marine diesel engines. This special arrangement can be found in one of the customer-specific sensors.



Unbalance and load detection in washing machines

Integrating displacement measurement into the washing machine damper helps to detect the imbalance and the loading of the drum. This measurement is performed using the cost-effective MDS-40-LP series sensor. A conventional hard ferrite magnet is integrated into the damper while the sensor board can later be clipped on from the outside.

Mounting options

Micro-Epsilon's magneto-inductive sensors can be applied in many different applications. In the case of non-ferromagnetic objects, the sensor can either be countersunk, flush mounted or protruding without any effects on the measurements. The magnet is mounted to the measurement object using a stainless steel screw, which is supplied with the sensor.



Measuring through non-ferromagnetic materials

Unlike conventional measuring methods, the magneto-inductive sensors enable measurements through non-ferromagnetic materials such as aluminium or stainless steel. A clear benefit is provided here as the sensor and the magnet can be installed separately in applications with closed systems or housings. It is therefore possible to mount the magnet safely in harsh environments and the sensor in protected areas.

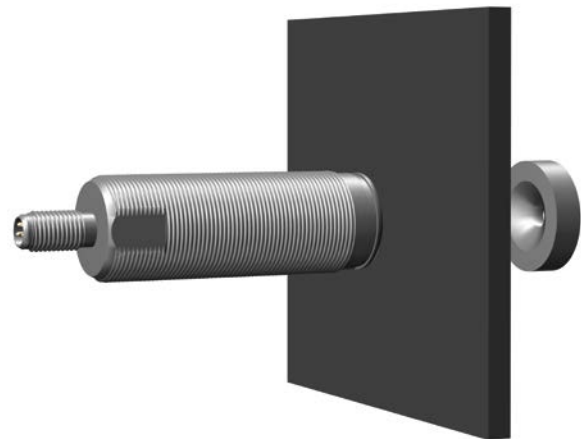

Axial and side shifted distance and displacement measurement

mainSENSOR detects the position of a magnet, which is fixed to the measurement object. The magnet can be applied to the sensor either axially or side on. Especially in the case of limited installation spaces, side shifted measurement offers a spacesaving alternative.

Axial measurement direction

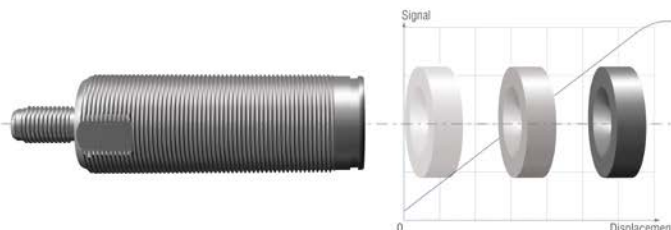

Side shifted measurement direction

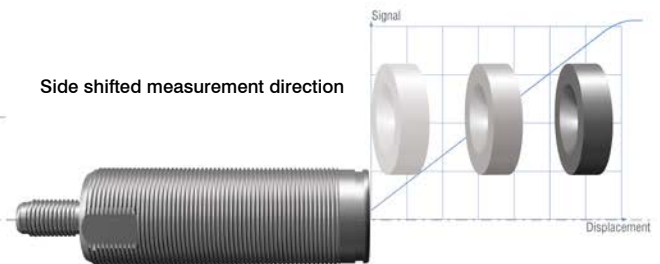

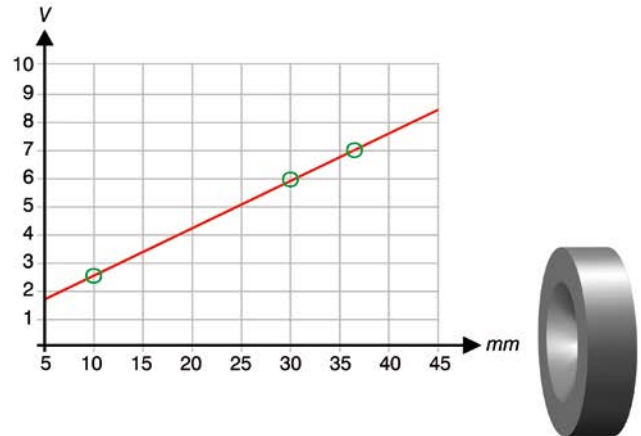

Advantages over inductive sensors

- Constant high sensitivity, even at the end of measuring range
- High protection class (fully metal housing)
- Compact design for large measuring ranges (e.g. M18 at 55mm measuring range)
- Flush mounting in non-magnetic materials
- Measurements on electrically conductive and non-magnetic materials (stainless steel, aluminium...)
- Excellent linearity

Ideal replacement for switches and proximity sensors

Magneto-inductive sensors are the preferred alternative for switching elements. The user can generate as many switching points as desired from the continuous analogue signal.

- No complex, mechanical adjustments are required for setting the switching point
- Definition of almost any number of switching points
- One sensor model suitable for many different distances

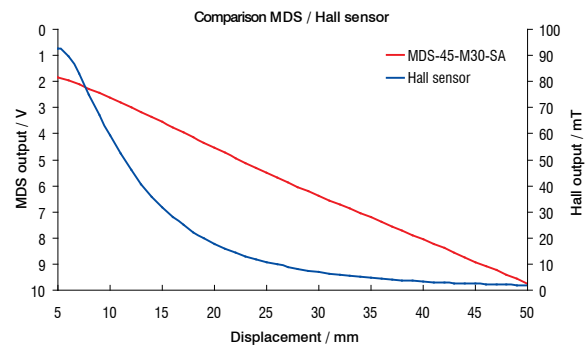
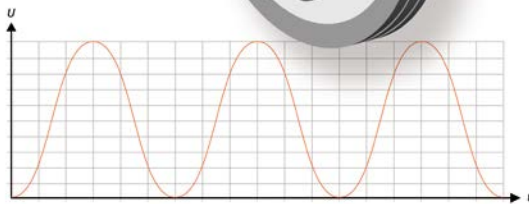

Rotational speed measurement

As well as distance and displacement measurement, mainSENSOR is also used for rotational speed measurement. In order to do so, one or two magnets are mounted on the rotating measuring object. Regardless of the direction of rotation, the sensor measures the speed of the target object. In the case of customer-specific solutions, the direction of rotation itself can also be detected. Therefore, two sensor components that detect and evaluate the direction of rotation increase are installed.

Advantages over magnetic sensor based on Hall Effect components

- Significantly longer measuring range
- Permanent output signal that is linear to the distance due to the measuring principle
- Significant advantages with regard to price for large measuring ranges
- Signal stability when magnet is not centered



MDS-45 is the industry-standard version of the magneto-inductive sensor. These stand out due to the common characteristics of this product series and also because of their very robust standard housing.

The sensors are available in M12, M18 and M30 stainless steel housings, as well as with a flat plastic housing. The stainless steel housing is ideally suited to demanding environments (dirt, oil, chemicals) and the food industry.

| Model | MDS-45-M12-CA | MDS-45-M18-SA | MDS-45-M18-HP-SA | MDS-45-M30-SA | MDS-45-K-SA |
|------------------------------------------|-----------------------------------------------------------------------------------------|--------------------------------------------|---------------------------|---------------------------------------------------------------------|-----------------------------------|
| Measuring range (standard) ¹⁾ | 45mm (further measuring ranges see accessories) | | | | |
| Offset distance ¹⁾ | 5mm | 2.25mm | | 4mm | |
| Linearity ^{1) 2)} | <3% FSO | | | | |
| Temperature stability | ±0.025 % FSO/K | | | | |
| Resolution ³⁾ | <0.05 % FSO | | | | |
| Frequency response (-3dB) | 1000Hz | | | | |
| Electrical connection | integr. cable 3m | M8x1, 4 pin, connector (screw and snap-on) | | | |
| Physical output parameter | Voltage | 2V ±0.3V ... 9.6V ±0.4V | | 2V ±0.2V ... 9.6V ±0.4V | 2V ±0.4V ... 9.6V ±0.4V |
| | Current | - | | 4 mA ±0.4mA ... 19.2mA ±0.8mA | 4mA ±0.8mA ... 19.2mA ±0.8mA |
| | | | | resistance (11.5V supply) ≤400Ω resistance (24V supply) ≤ 800Ω | |
| Storage temperature | -20°C ... +80°C | | | | |
| Operating temperature | -20°C ... +80°C | | | | |
| Power supply | 11.5V _{DC} ... 30V _{DC} | | | | |
| Current consumption | max. 20mA | | | max. 20mA (with voltage output); max. 40mA (with voltage output) | |
| Protection class | IP67 (with plug variants only in mated condition) higher protection class on request | | | | |
| Pressure resistance (static) | 100 bar (at the front) | 100 bar (at the front) | 400 bar (at the front) | 40 bar (at the front) | - |
| Vibration | DIN EN 60068-2-6 (20g, 58 - 500Hz) | | | | |
| Shock | DIN EN 60068-2-29 (40g, 6ms, 1000 cycles) DIN EN 60068-2-27 (100g, 6ms, 3 cycles) | | | | |
| EMC | EN 61326-1:2006; EN 61326-2-3:2007 | | | | - |
| Housing material | Stainless steel | | | | Plastics / nickel plated brass |
| Weight (excluding screw nuts) | appr. 60g | appr. 40g | | appr. 110g | appr. 25g |

FSO = Full Scale Output

¹⁾ Measuring changes by using other magnets (see page 14); External magnetic fields and/or ferromagnetic material in the measuring range of the sensor system affect the sensor characteristic line and the measuring range.

²⁾ Deviation to the regression curve according to the method of the least squares

³⁾ Peak-Peak; external low pass; frequency response 5kHz

MDS-45-M12-CA

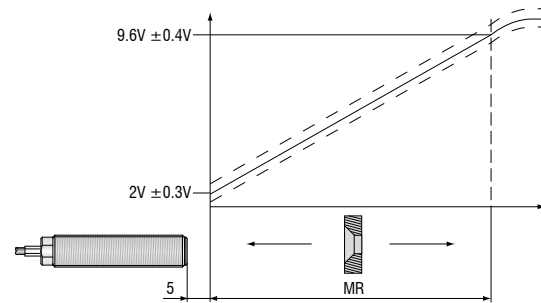
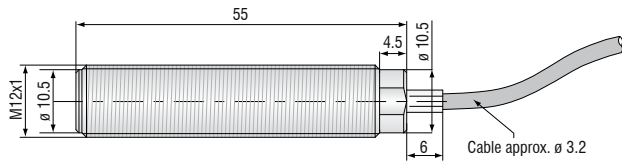

MDS-45-M18-SA / MDS-45-M18-HP-SA

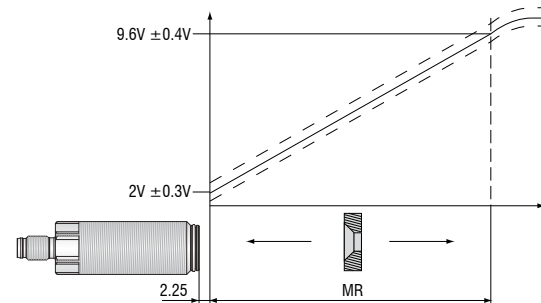
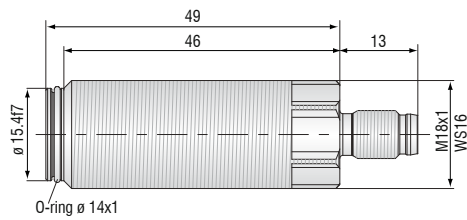

MDS-45-M30-SA

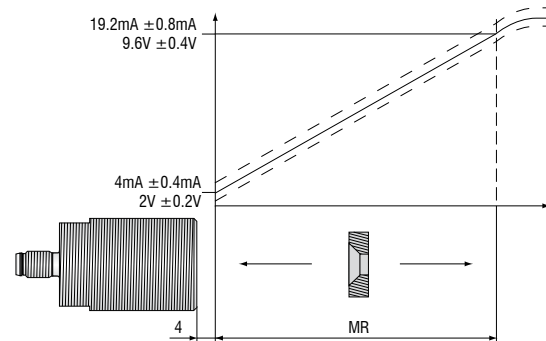
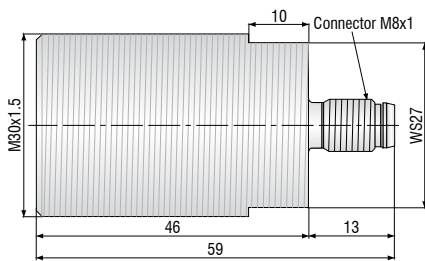

MDS-45-K-SA

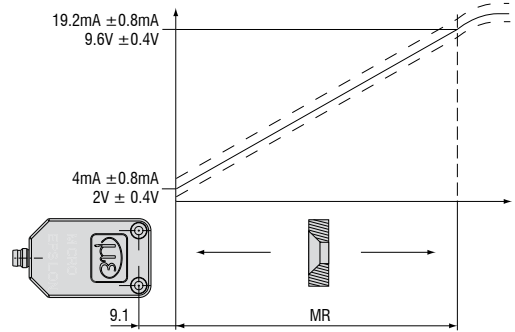
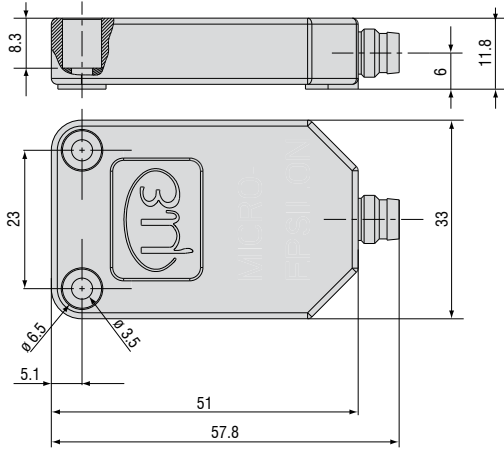

Accessories

Power and output cable for fully metal sensors

- Art.No. 2901617 PC5/4 (5m, shielded, straight connector, PUR, open ends)
- Art.No. 2901600 PC5/4/90 (5m, shielded, 90° connector, PUR, open ends)

Power and output cable for sensors made from plastics

- Art.No. 2901599 PC5/4(01) (5m, unshielded, straight connector, PUR, open ends)
- Art.No. 2901600.01 PC5/4/90(01) (5m, unshielded, 90° connector, PUR, open ends)

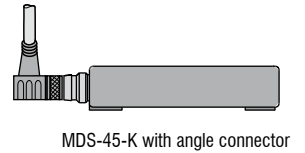
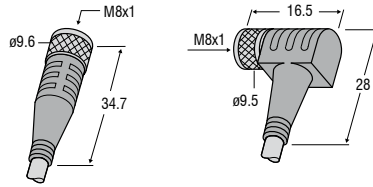
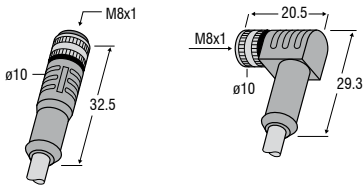

| Pin | Function | Color | Description |
|--------|------------------|-------|-----------------------------------------|
| 1 | V _{cc} | brown | Power supply 11.5V...30V |
| 2* | I _{out} | white | Output signal 4mA...20mA |
| 3 | GND | blue | Ground |
| 4 | U _{out} | black | Output signal 2V...10V |
| Shield | | | Please connect the shield to the ground |

* Pin only used for sensors with current output

Pin assignment
View connector side

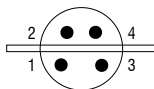



The sensors of the MDS-40-MK series are a new generation of cost-effective and flexible magneto-inductive sensors. In addition to the pre-configured preferred types, a combination of further options (power supply, output, plug,...) for serial or industrial applications is possible.

Possible combinations

The following combinations are possible from a quantity of 200 pieces.

Selectable options

MDS - 40 - MK - SA8 - I - 1130 - IP20 - FIX

FIX: supporting surface for curved surfaces

Protection class: IP67 (casting)
IP20V (partial casting)
IP20 (not moulded)

Supply: 1130 (11 - 30V)
5 (5V)
33 (3.3V)

Output: I (4 - 20mA)
U10 (2 - 10V)
U45 (0.5 - 4.5V)
U45R (0.5 - 4.5V, ratiometric)
F (Frequency: time measurement)

Connector: SA8 (M8x1, axial)
SR7 (JST JWPF, radial)
SR0 (JST PA, radial)

| | | Supply | | |
|--------|------|--------|---|----|
| | | 1130 | 5 | 33 |
| Output | I | • | - | - |
| | U10 | • | - | - |
| | U45 | • | • | - |
| | U45R | - | • | • |
| | F | • | • | • |

| | | Connector / cable | | |
|------------------|------|-------------------|-----|-----|
| | | SA8 | SR7 | SR0 |
| Protection class | IP20 | • | • | • |
| | IP67 | • | • | - |

- Combination possible
- Combination not possible

Main measurement direction

The above-mentioned data refer to the main measurement direction; however, other magnet arrangements and directions of movement are possible and can result in a change of the characteristic line.

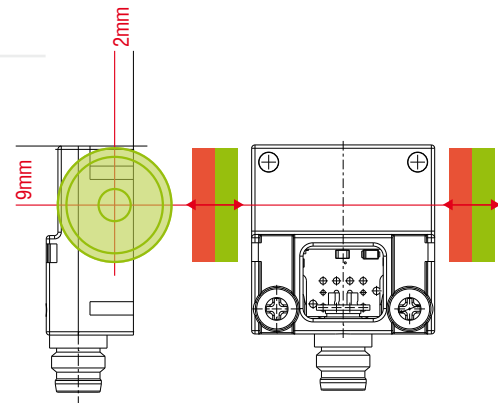

| Modell | Preferred types | | | | MDS-40-MK-XXX |
|---------------------------------------|--------------------------------------------------------------|-----------------------------------|---------------------------|------------------------------------|---------------|
| | MDS-40-MK-SA8-I | MDS-40-MK-SR7-U10 | MDS-40-MK-SR7-U45R | MDS-40-MK-SR0-F | |
| Measuring range ¹⁾ | RL21 magnet: 30mm (further measuring ranges see accessories) | | | | |
| Offset distance ¹⁾ | RL21 magnet: 1.5mm | | | | |
| Linearity ^{1) 2)} | <3% ±5% FSO | | | | |
| Temperature stability | ±500 ppm FSO / K | | | | |
| Resolution ³⁾ | <0.05 % FSO | | | | |
| Frequency response / Square frequency | 1000Hz (-3dB) | | | typ. 402 - 285 Hz (square) | |
| Electrical connection | connector axial, M8x1, 4 pin | connector radial, JST JWPF, 4 pin | | connector radial, JST PA, 4 pin | selectable |
| Output | 4...20mA | 2...10V | 0.5V...4.5V (ratiometric) | frequency (time measurement, p.15) | selectable |
| Storage temperature | -20°C...80°C | | | | |
| Operating temperature | -20°C...80°C | | | | |
| Power supply | 11...30 VDC | | | 5 VDC | selectable |
| Protection class | IP67 (casting) | | | IP20 (partial casting) | selectable |
| Housing materials | PA 66 / brass / PUR | | | | |
| Packaging unit | 1 pc | | 10 pc | | from 200 pc |

FSO = Full Scale Output

¹⁾ Measuring changes by using other magnets (see page 14); external magnetic fields and/or ferromagnetic material in the measuring range of the sensor system affect the sensor characteristic line and the technical data

²⁾ Deviation to the regression curve according to the method of the least squares

³⁾ Peak-Peak; external low pass; frequency response 5kHz

Option SA8

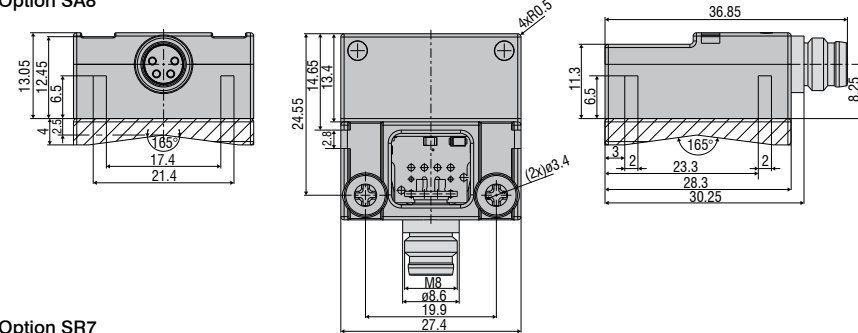

Pin assignment

View connector side

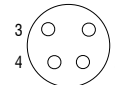

- 1: + supply
 - 2: GND Out
 - 3: GND
 - 4: + Out
- GND pins internally connected

Option SR7

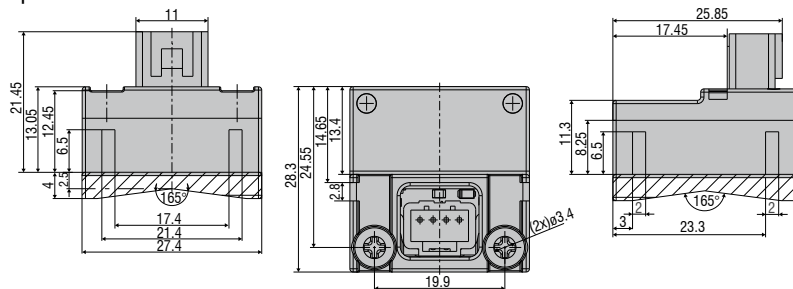

Pin assignment

View connector side

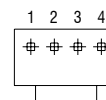

- 1: + supply
 - 2: GND Out
 - 3: GND
 - 4: + Out
- GND pins internally connected

Option SR0

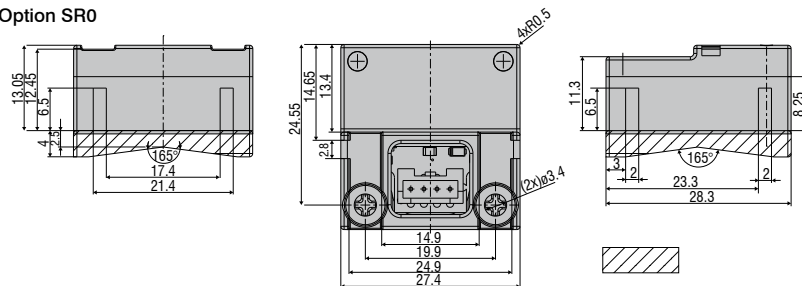

Pin assignment

View connector side

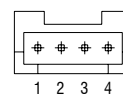

- 1: + supply
 - 2: GND Out
 - 3: GND
 - 4: + Out
- GND pins internally connected

Optional retaining plate not included in delivery



The MDS-40-LP sensors are specially designed for large volume production from 2,000 pieces or more. As these sensors are reduced to pure measurement technology, the creation of cost-effective PCB sensors was possible. Their flat design and flexible arrangement

of the magnets allows easy integration in restricted spaces. Measured values are output via a rectangular signal, which is easily evaluated via, for example, digital inputs from micro-controllers.

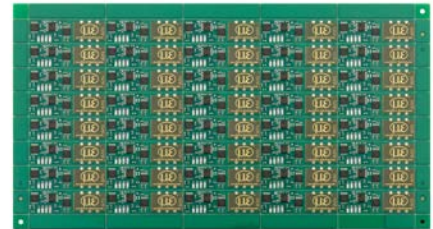

| OEM sensor example | MDS-40-LP-SUS | MDS-40-LP-F |
|---------------------------------|--------------------------------------------------------|--------------------------------------------------------|
| Measuring range ¹⁾ | 40mm | 40mm |
| Linearity ²⁾ | <6 % FSO | <9 % FSO |
| Temperature stability | ±0.06% FSO/K | ±0.2% FSO/K |
| Resolution | <0.05% FSO | <0.05% FSO |
| Physical output parameter | Period duration Rectangle: typ. 2.0ms ... 3.3ms (p.15) | Period duration Rectangle: typ. 1.0ms ... 1.7ms (p.15) |
| Operating temperature | -20°C ... +85°C | |
| Supply voltage ³⁾ | 3.6V _{dc} ... 5.3V _{dc} | |
| Power consumption ⁴⁾ | typ. 15mA (5V) 12mA (3.6V) | |
| Typ. dimensions | 50 x 15 x 3mm | 20.8 x 14.8 x 3mm |
| Electrical connection | Plug-in connection to a PCB; grid size 2.5mm | |
| Minimum quantity | 2,000 pc | 5,000 pc |

FSO = Full Scale Output

¹⁾ Measuring changes by using other magnets (see page 14); external magnetic fields and/or ferromagnetic material in the measuring range of the sensor system affect the sensor characteristic line and the technical data

²⁾ Deviation to the regression curve according to the method of the least squares

³⁾ Without inverse polarity protection, without overvoltage protection

⁴⁾ Without output load



Application example: Integration into a washing machine damper

Sensors for customer-specific requirements

Sensors can be adapted in many different ways to suit customer-specific applications. Particularly in the case of high volume orders, customized sensors can be produced efficiently, which results in considerable cost reductions.

The compact PCB which contains the sensor element and the evaluation electronics, is responsible for the signal preparation, signal evaluation and signal output. Furthermore, the PCB is adapted to customer-specific requirements. This means that the measurement mode (distance or speed measurement) and the accuracy requirements, as well as the required frequency response, can be selected. In addition, the interfaces offer numerous connectivity options. There are several outputs such as current, voltage, PWM and further digital outputs. The design of the housing, the material and the protection class can be adapted to the specific requirements. In cases where space is limited, the side shifted measurement offers a spacesaving alternative. For harsh environments, the sensor is designed with a fully sealed stainless steel housing that withstands high pressure, dirt, aggressive chemicals (acids) and solvents.

Overview of customer-specific solutions

- High cost efficiency in the case of high-volume production
- Ideal for miniature applications
- Flexible design (sensor on PCB)
- Side shifted measurement (dampers arrangement)
- Output signal (current, voltage, PWM...)
- Increased pressure resistance
- Frequency response up to 20kHz

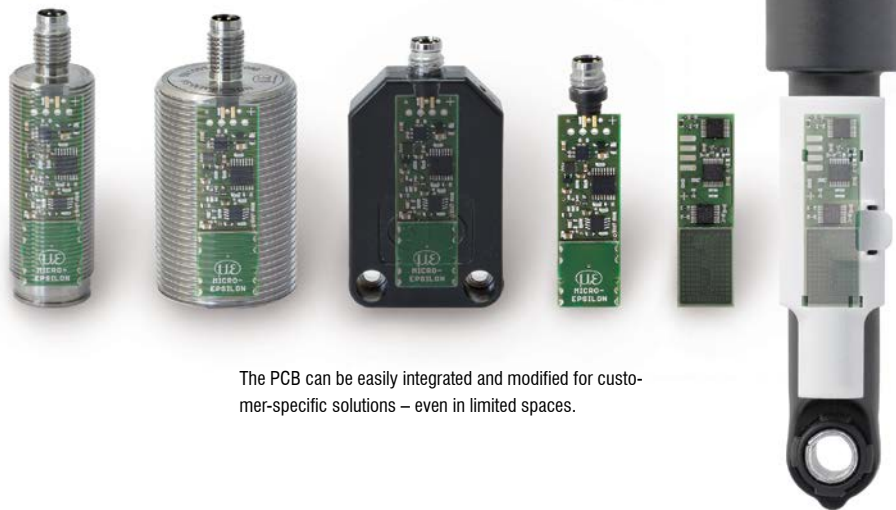

The PCB can be easily integrated and modified for customer-specific solutions – even in limited spaces.

Customer-specific versions for rotational speed measurement with pre-tensioned sensors

For rotational speed measurements of ferromagnetic objects such as toothed racks, the sensor can be pre-tensioned. This means that the magnet is integrated to the housing. For this customer-specific solution a factory calibration is required. The movement of the toothed racks affects the magnetic field, which is required for the speed measurement. The speed measurement can also be carried out through non-ferromagnetic materials.

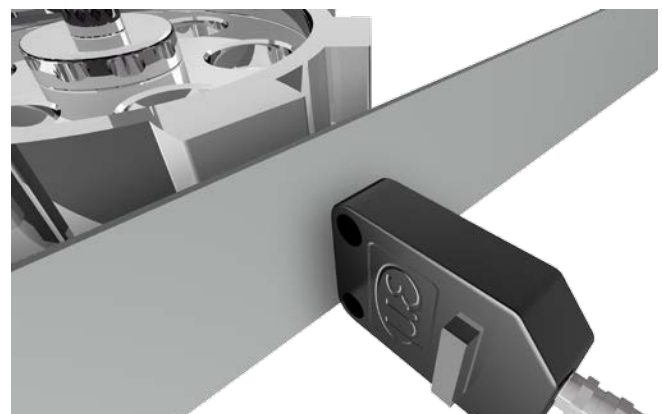

Pre-tensioned sensor for speed measurement of toothed racks

Magnets

The magnets are critical components of the magneto-inductive measuring principle.

Many shapes and materials are available. Application, installation space, temperature and cost factors must be considered. A decisive advantage is that the measuring range of the sensor can be defined by selecting the appropriate magnet. Adapting or set up of the sensor are unnecessary.

Therefore, measuring ranges of 20 to 55mm can be achieved using only one sensor.

Simple change of the measuring range by exchanging the magnet

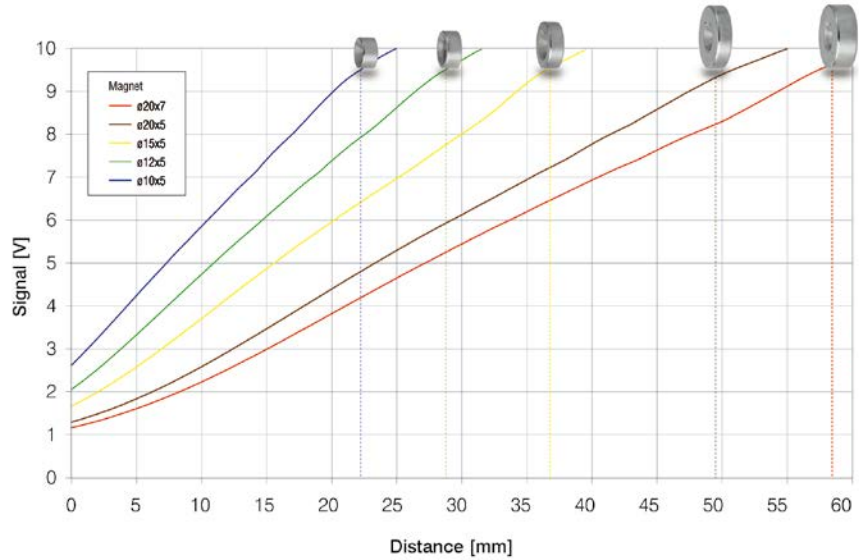

| Description | Measuring range MDS-45 [mm] | Measuring range MDS-40-MK [mm] | T _{max} [°C] | Standard magnets | | | | Standard magnets with protection housing | | | | | | |
|-------------|-----------------------------|--------------------------------|-----------------------|----------------------|----|-----|-----|------------------------------------------|----------------------|----|-----|---|----|-----|
| | | | | Material | D | D1 | D2 | H | Material | D | H | L | M | S |
| MB20 | 20 | - | 150 | NeFeB, nickel-plated | 10 | 4.3 | 8.6 | 5 | 1.3964 Nitronic 50HS | 16 | 9.5 | 5 | M4 | 2 |
| MB27 | 27 | ~ 23 | 150 | NeFeB, nickel-plated | 12 | 4.3 | 8.6 | 5 | 1.3964 Nitronic 50HS | 16 | 9.5 | 5 | M4 | 2 |
| MB35 | 35 | ~ 33 | 150 | NeFeB, nickel-plated | 15 | 4.3 | 8.6 | 5 | 1.3964 Nitronic 50HS | 26 | 14 | 7 | M6 | 3.5 |
| MB45 | 45 | ~ 45 | 150 | NeFeB, nickel-plated | 20 | 4 | 8 | 5 | 1.3964 Nitronic 50HS | 26 | 14 | 7 | M6 | 3.5 |
| MB55 | 55 | ~ 50 | 150 | NeFeB, nickel-plated | 20 | 4 | 8 | 7 | 1.3964 Nitronic 50HS | 26 | 14 | 7 | M6 | 3.5 |
| RL21 | 33 | ~ 30 | 200 | SrFe, hard ferrite | 20 | 4.3 | - | 10 | - | - | - | - | - | - |
| RL20 | 25 | ~ 25 | 200 | SrFe, hard ferrite | 20 | 4.3 | - | 6.5 | - | - | - | - | - | - |

Magnets at higher temperatures

Permanent magnets present reversible and irreversible temperature dependence. With low temperatures, the magnetic field changes reversibly with the temperature. In the first approximation, this dependence is linear. Irreversible attenuations of the magnetic field are caused by rising temperatures. The main part of these attenuations arises when the temperature is reached for the first time. Therefore, it is recommended that when using magnets in high temperatures, they are heated up only once to the operating temperature or to around 20°C above the operating temperature, provided that the respective magnet specification allows this. Please refer to Micro-Epsilon TechNote T016 for further details.

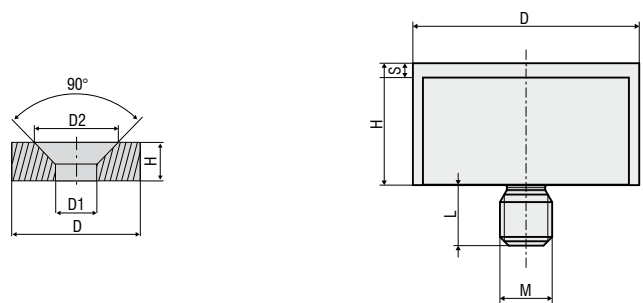

A pressure housing is a method of protecting a magnet from high pressure or aggressive media. This is made from robust stainless steel and resists pressures up to 400 bar.

Rectangular output signals

For OEM sensors an effective signal conditioning is mandatory to gain the best price/performance ratio. Therefore all sensors of the series MDS-40 are offering a rectangular output signal, that is easy to create, but also easy to evaluate. Important is the capability to measure times, e.g. with a micro controller. Depending on the type of magnet, the distance signal is proportional to the period of duration or the frequency of the rectangular signal.

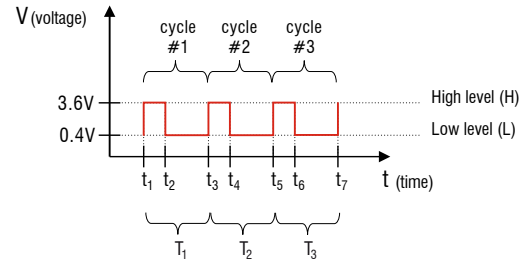

Series MDS-40-LP-F

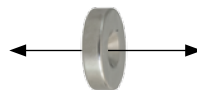
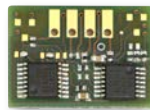
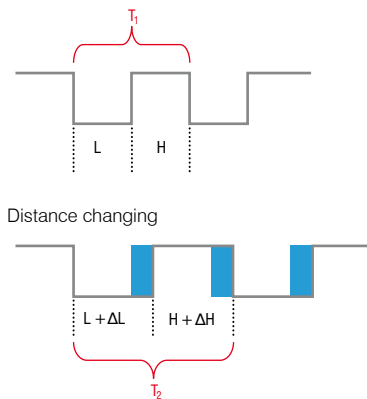

L = time at a low level
 H = time at a high level
 H and L ~ distance signal

Series MDS-40-LP-SUS

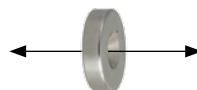
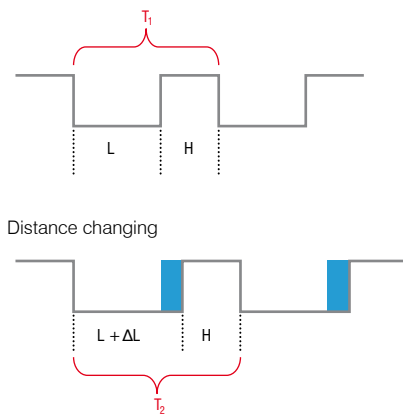

L = time at a low level
 H = time at a high level
 L ~ distance signal
 Details about temperature compensation are available on request

Series MDS-40-MK

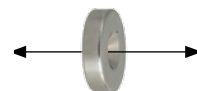
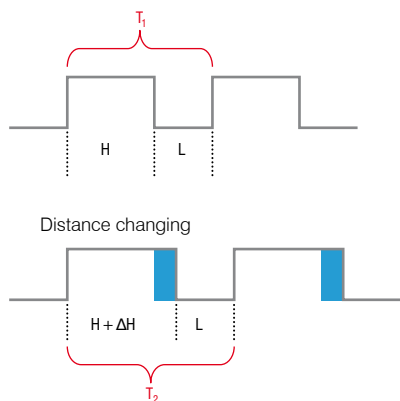

L = time at a low level
 H = time at a high level
 $1/(H+L) = f$ ~ distance signal

High performance sensors made by Micro-Epsilon



Sensors and systems for displacement and position



Sensors and measurement devices for non-contact temperature measurement



2D/3D profile sensors (laser scanner)



Optical micrometers, fiber optic sensors and fiber optics



Color recognition sensors, LED analyzers and color online spectrometer



Measurement and inspection systems



SCIGATE AUTOMATION (S) PTE LTD

No.1 Bukit Batok Street 22 #01-01 Singapore 659592

Tel: (65) 6561 0488

Fax: (65) 6562 0588

Email: sales@scigate.com.sg

Web: www.scigate.com.sg

Business Hours: Monday - Friday 8.30am - 6.15pm



MICRO-EPSILON

MICRO-EPSILON USA

8120 Brownleigh Dr. · Raleigh, NC 27617 / USA

Phone +1/919/787-9707 · Fax +1/919/787-9706

me-usa@micro-epsilon.com · www.micro-epsilon.com